



SIA SSB Group

Payment Service Directive SIA-SSB Value Proposition

Mario De Lorenzo





SIA SSB Group

Payment Services Directive: SIA-SSB Value Proposition

PSD Introduction and Impacts

SIA-SSB for PSD



SIA SSB Group

SIA-SSB Value Proposition for PSD PSD Context

Why PSD?

- Creation of a common legal framework for SEPA instruments
- Protection of Customers business needs and rights
- System deregulation with new competitors as PSP

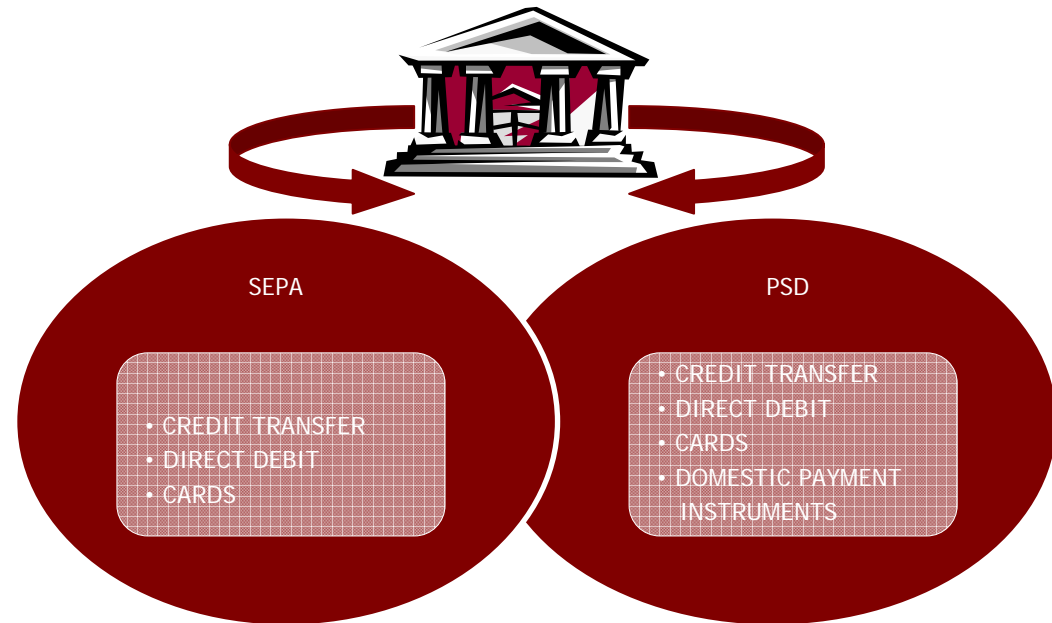



SIA SSB Group

SIA-SSB Value Proposition for PSD PSD Impact areas for Banks

- Contracts and Terms & Conditions
- Customer Communication and Reporting
- Business Application
- Risk Management
- Data Archiving





SIA SSB Group

SIA-SSB Value Proposition for PSD PSD Consequences

- Higher costs for Information System upgrading and procedures for compliance
- Possible decrease of revenues from domestic and cross border payment instruments
- Higher competition between banks and with new Payment Institutions





SIA SSB Group

SIA-SSB Value Proposition for PSD How to tackle PSD?

- Smart investments in order to
 - reduce costs
 - increase efficiency
 - set the ground for new services
- Innovation and new business opportunities





SIA SSB Group

Payment Services Directive: SIA-SSB Value Proposition

PSD Introduction and Impacts

SIA-SSB for PSD



SIA SSB Group

SIA-SSB Value Proposition for PSD European Banks most common approach

Pre-PSD Situation

- **Silos Architecture**
 - Different approaches for different business applications
 - Lack of cross data view
 - High maintenance costs

Financial crisis and SEPA introduced budget reduction and time constraints therefore most banks have limited the effort for achieving PSD compliance



PSD initial phase

- **Minimum IT systems upgrade to cover compliance**
- **PSD data still distributed between different Applications**
- **Introduction of manual procedures to fill technical gaps**
- **Postponement of more advanced and structured solutions**



SIA SSB Group

SIA-SSB Value Proposition for PSD

SIA-SSB PSD suite

PSD maturity phase

- reduce costs
 - Remove all manual activities and introduce full STP: better service for Bank's customers and reduced costs
- increase efficiency
 - Composed by several independent modules
 - Available information reusing
 - Single window for all services
- new services
 - Single database able to provide internal and external users with much richer set of information

Existing Applications

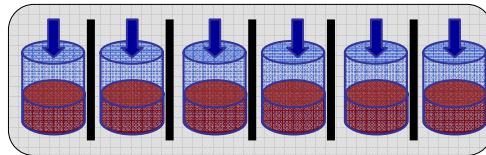

PSD Suite

Tracking

Monitoring

Paper Documents dematerialization

Staging Area

SLA



WEB

- Common services and interface
- Standardization of rules
- Processes optimization
- Easy installation and integration
- Customizable
- Flexible Real Time & Batch data transfer



SIA SSB Group

SIA-SSB Value Proposition for PSD

SIA-SSB proposal: horizontal approach

- Record all events
- Full payment's order cycle coverage with all data details
- Data export to Microsoft Excel and/or PDF format

- Provides alert for warning, errors, events impacting SLA
- Full payment's order cycle management
- Data export to Microsoft Excel and/or PDF format

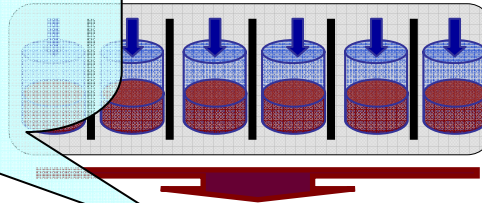

- Record all information related to payment and card operations
- Historical information as for PSD (13 months)
- Refund management
- Single or aggregated inquiries
- Summary information about counterparts and instruments

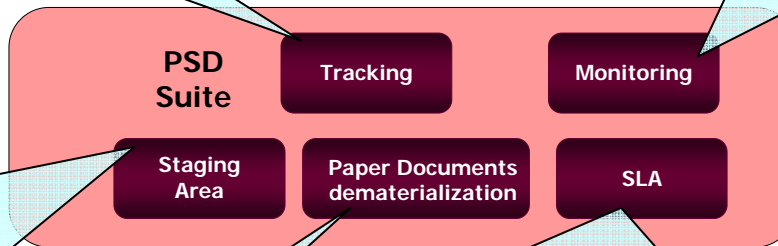

- Allow electronic archiving for all paper based documents
- Cover legal requirements for dematerialization
- Stored documents can be used to complement Staging Area information

- Service levels and statistics
- Rules-based module
- Management and control of overall processes
- Export data (Excel or text files)
- Fine tuning and simulation for Service levels using new parameters and searching criteria
- Re-run on stored data

SIA-SSB Group role in PSD playground



SIA SSB Group

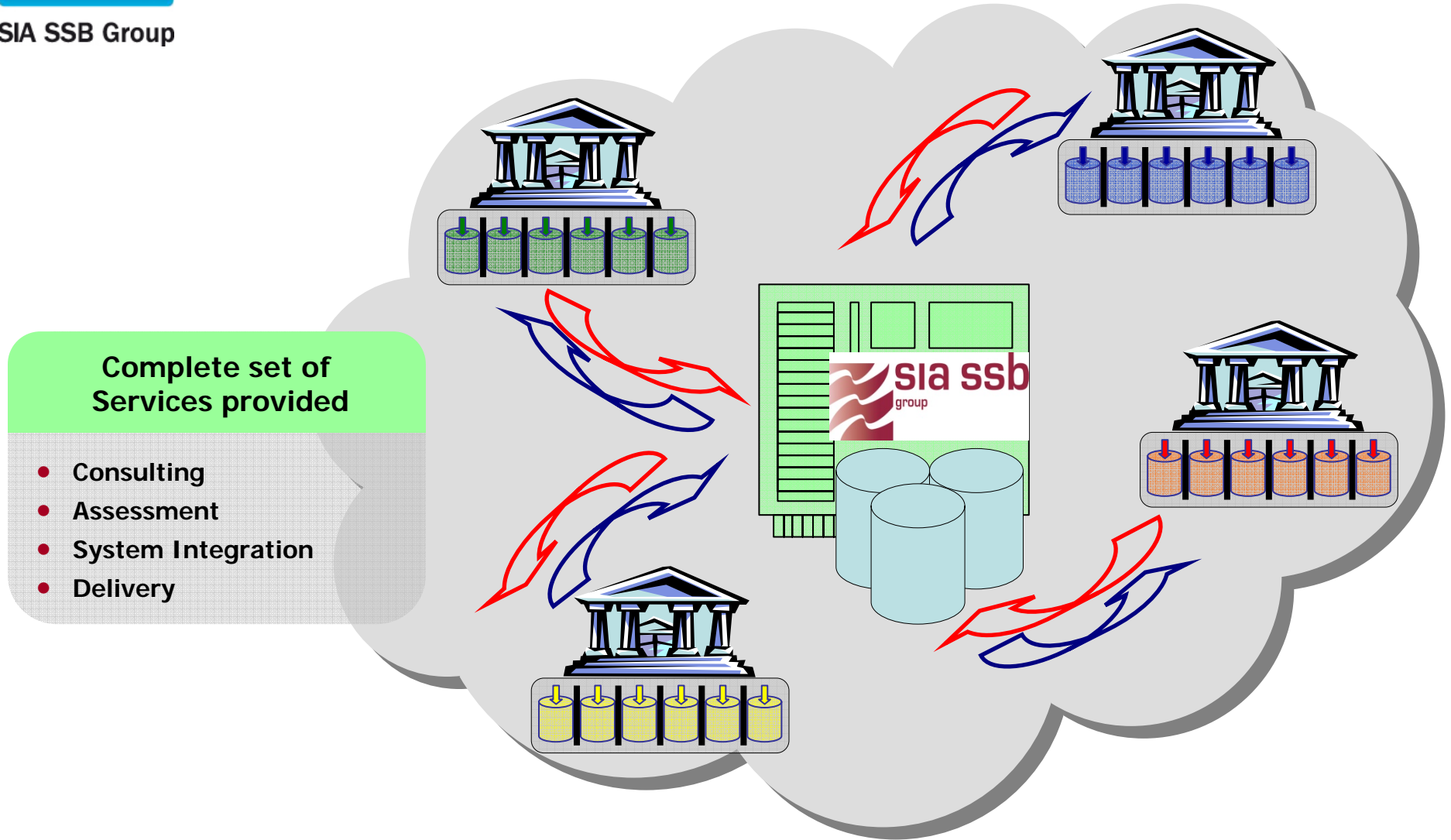

Complete set of Services provided

- Consulting
- Assessment
- System Integration
- Delivery



SIA SSB Group

www.gbc.hu

Mario De Lorenzo

mario.delorenzo@siassb.eu

